

AGIPRO™

●●●● SMALL-SIZED TOP-ENTRY AGITATOR

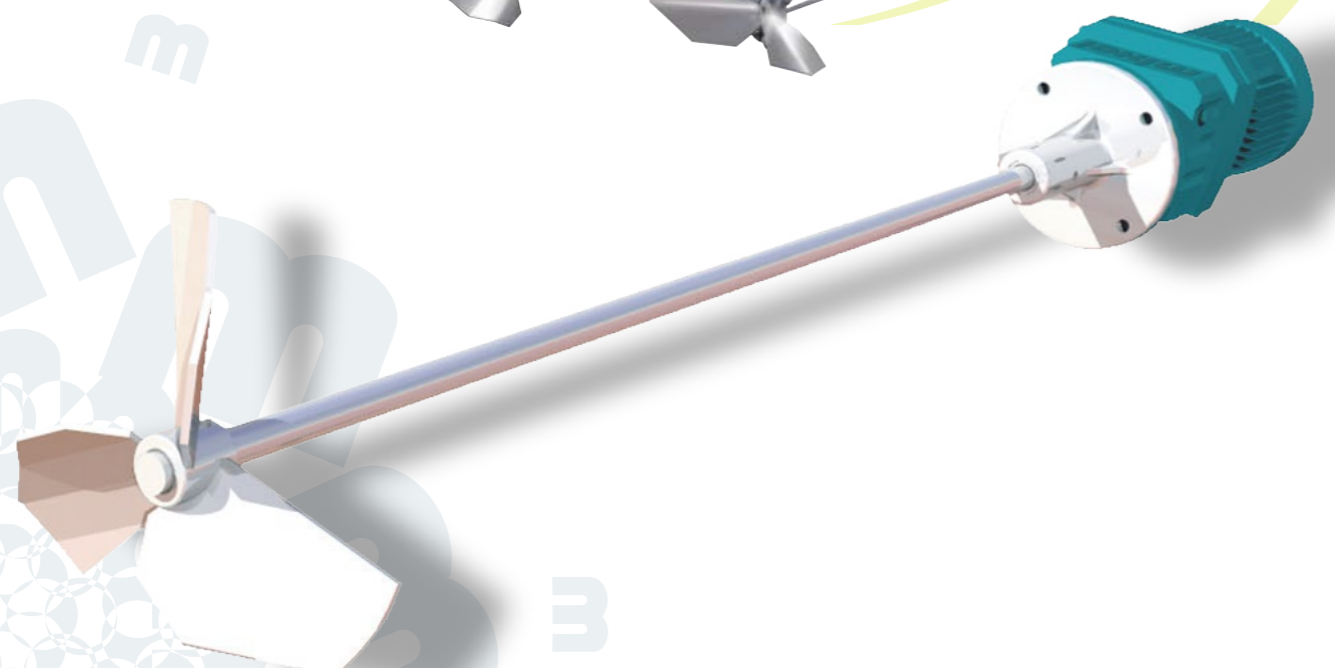

- Multi-purpose
- Energy saving and high efficiency
- Simple structure
- Easy to handle



Tank volume: 0.5 m³~8 m³

- MIXING
- HOMOGENIZATION
- SUSPENDING SOLIDS

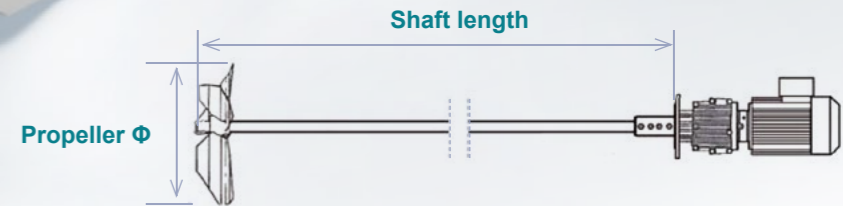
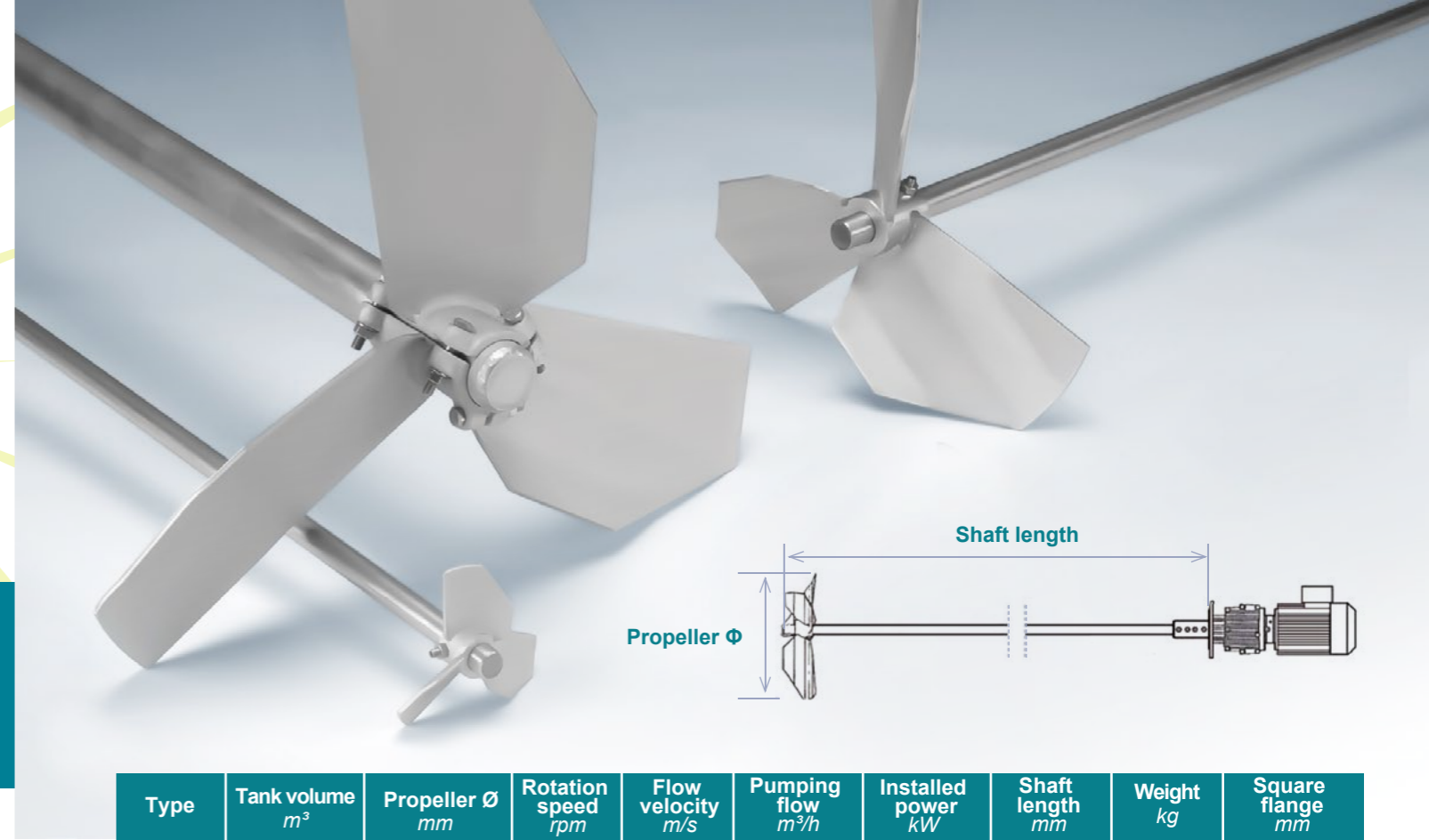

Type	Tank volume m ³	Propeller Ø mm	Rotation speed rpm	Flow velocity m/s	Pumping flow m ³ /h	Installed power kW	Shaft length mm	Weight kg	Square flange mm
AP125	0.5 to 1.5	125	1425	3.57	158	0.75	1200	15	250 x 250
AP250	1.5 to 3	250	280	1.48	261	0.37	1500	20	
AP400	3 to 5	400	145	1.33	600	0.55	1500	30	400 x 400
AP600	5 to 8	600	123	1.17	1196	1.1	2000	60	

Voltage 380V three-phase - 50 Hz - protection degree IP55

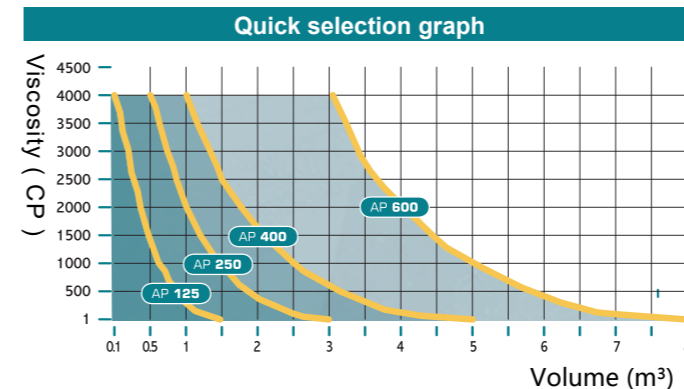

Suitable for all liquid mixtures (viscosities 1 to 4000CP)

Water Treatment	<ul style="list-style-type: none"> ✓ Conditioning in tanks ✓ Flocculation ✓ Reagent preparation ✓ Coagulation 	
Industrial effluent Treatment	<ul style="list-style-type: none"> ✓ Neutralisation ✓ PH adjustment ✓ Urea preparation 	
Paint	<ul style="list-style-type: none"> ✓ Paint preparation ✓ Aqueous phase 	
Paper	<ul style="list-style-type: none"> ✓ Varnish preparation (starch + dyes) 	
Other industries	<ul style="list-style-type: none"> • Food-processing • Chemistry • Cosmetics • Etc. 	<ul style="list-style-type: none"> ✓ All process works that need to keep the product suspended

- Available accessories
- Stainless steel clamp - suitable for tank edge installation
 - Stainless steel mounting bottom cover - suitable for tank top mounting
 - Steel galvanized brackets - suitable for container top mounting
 - Rubber, various polymer coatings - suitable for special conditions such as corrosion and abrasion

