

SEALBOX™

TOP-ENTRY AGITATOR WITH MECHANICAL SEAL

- Satisfy a variety of mixing requirements
- Compact structure and small space occupancy
- Suitable for small but precise processes
- Integrated design of machine seal and frame
- Convenient disassembly

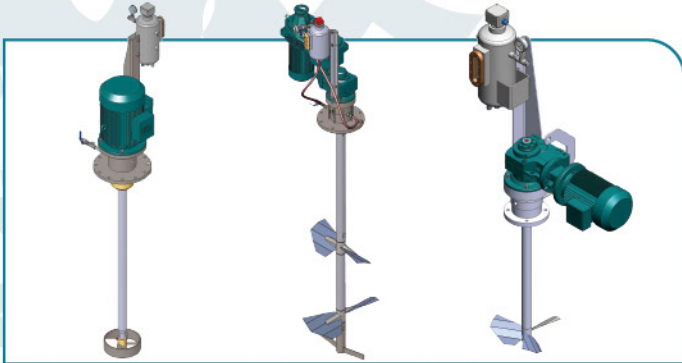
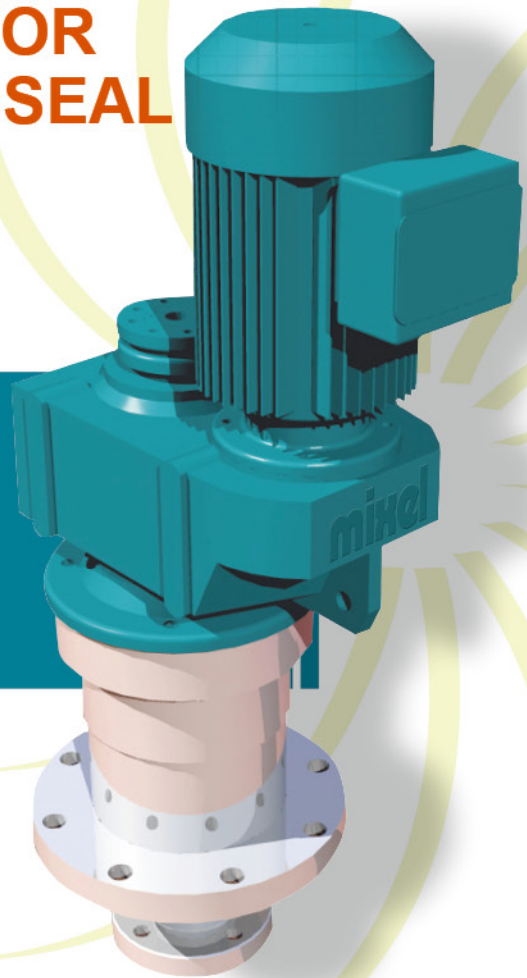

Application: Petrochemical industry

Application

Mixing, storage, dispersion, dissolution, solid suspension, emulsification

Design

Diameter of mechanical seal up to 80mm
Reducer motor power up to 11kW
Stirring shaft length up to 2500mm
The temperature up to 300°C
Pressure in the tank up to 25bar

Material

Carbon steel, stainless steel, alloy, coated steel and special materials